



EC type-examination certificate

Certificate no.: AGB 264

Notified body: TÜV SÜD Industrie Service GmbH
Westendstr. 199
80686 München - Germany

**Applicant/
Certificate holder:** Hans Jungblut GmbH & Co. KG
Ostheimer Straße 171
51107 Köln - Germany

Date of application: 2013-09-12

**Manufacturer of the test
sample:** Hans Jungblut GmbH & Co. KG
Ostheimer Straße 171
51107 Köln - Germany

Product: Overspeed Governor

Type: GB 160

Test laboratory: TÜV SÜD Industrie Service GmbH
Prüflaboratorium für Produkte der Fördertechnik
Prüfbereich Aufzüge und Sicherheitsbauteile
Westendstr. 199
80686 München - Germany

**Date and
number of the test report:** 2014-05-22
AGB 264

EC-Directive: 95 / 16 / EC

Result: The safety component conforms to the essential safety requirements of the Directive for the respective scope of application stated on page 1 - 2 of the annex to this EC type-examination certificate.

Date of issue: 2014-05-23

Certification body for lifts and safety components
Identification number: 0036

Chadi Nouredine
Chadi Nouredine



**Annex to the EC type-examination certificate
no. AGB 264 dated 2014-05-23**

1 Scope of application

1.1	Permissible tripping speed	0.30 – 1.50 m/s
1.2	Permissible rated speed	≤ 1.30 m/s
1.3	Driving rope	
1.3.1	Type	Steel wire rope of Drako 250T series
1.3.2	Diameter	6 – 6.5 mm
1.3.3	Construction / Type	8x19W + IWRC sZ U
1.3.4	Minimum breaking load	26.8 kN – 31.5 kN
1.4	Minimum tension forces (force produced by the tensioning weight, acting on the axis of rope deviating pulley)	
1.4.1	Tensioning force determined in the test (New rope and groove)	816 N
1.5	Tensile force at minimum tension force	> 300 N

2 Conditions

2.1 Discarding condition of the rope

- 26 broken wires within a length of 30 x d or
- 13 broken wires within a length of 6 x d or
- a diameter reduction of more than 6% related to the nominal rope diameter

2.1 Remarks on standard design

- The adjusted tripping speed and the safety switch must be sealed against unauthorised adjustment (safety switch, for example by colour sealing of the fastening screws and only if switching off is required prior to achieving the tripping speed)
- Retraction of the safety gear in both direction of rotation is permissible. The standard design with one direction of rotation for retracting the safety gear is to be marked at the overspeed governor
- Swinging lever (pendulum) installed in up or down position
- Mounting position turned through 180° (console for fastening in upper position)
- Deflection of rope optional (but at least 180° angle of wrap)
- Design with or without testing groove

- 2.3 Remarks on variable arrangement and attachments to the standard design
- Switching off prior to achieving the tripping speed (preliminary switch off, optionally with electrical re-setting of safety switch)
 - Design with or without remote release
 - Protection against lowering with monitoring of rest position
 - Installation suspending in the shaft pit
 - Applying an encoder by shaft out jutting (direct actuation), optionally indirect by belt drive
 - Magnetic switch and inductive proximity switch fitting (mounted side component) possible

- 2.4 In order to provide identification, information about the basic design and functioning and to show the environmental conditions and connection requirements pertaining to the tested and approved type, and to define which parts have been tested, drawing no. GB 160-U or GB 160-U-P with certification stamp dated 2014-05-23 is to be enclosed with the EC type-examination certificate and the annex thereto.

3 **Remarks**

- 3.1 The EC type-examination certificate may only be used in connection with the pertinent annex and the list of the authorized manufacturers (according to enclosure). This enclosure shall be updated and re-edited following information of the certificate holder.

GB 160 - U

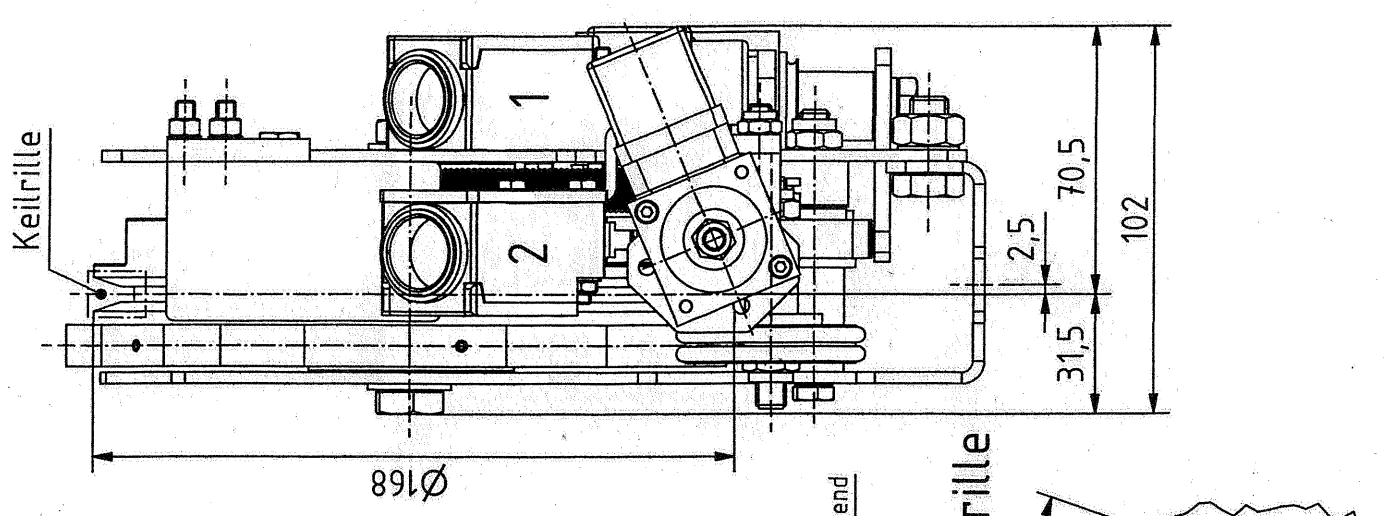

Detail Keilrille

Seilabsprungschutz (optional)

Typenschild

Fernauslösung (optional)

Fangpendel untenliegend

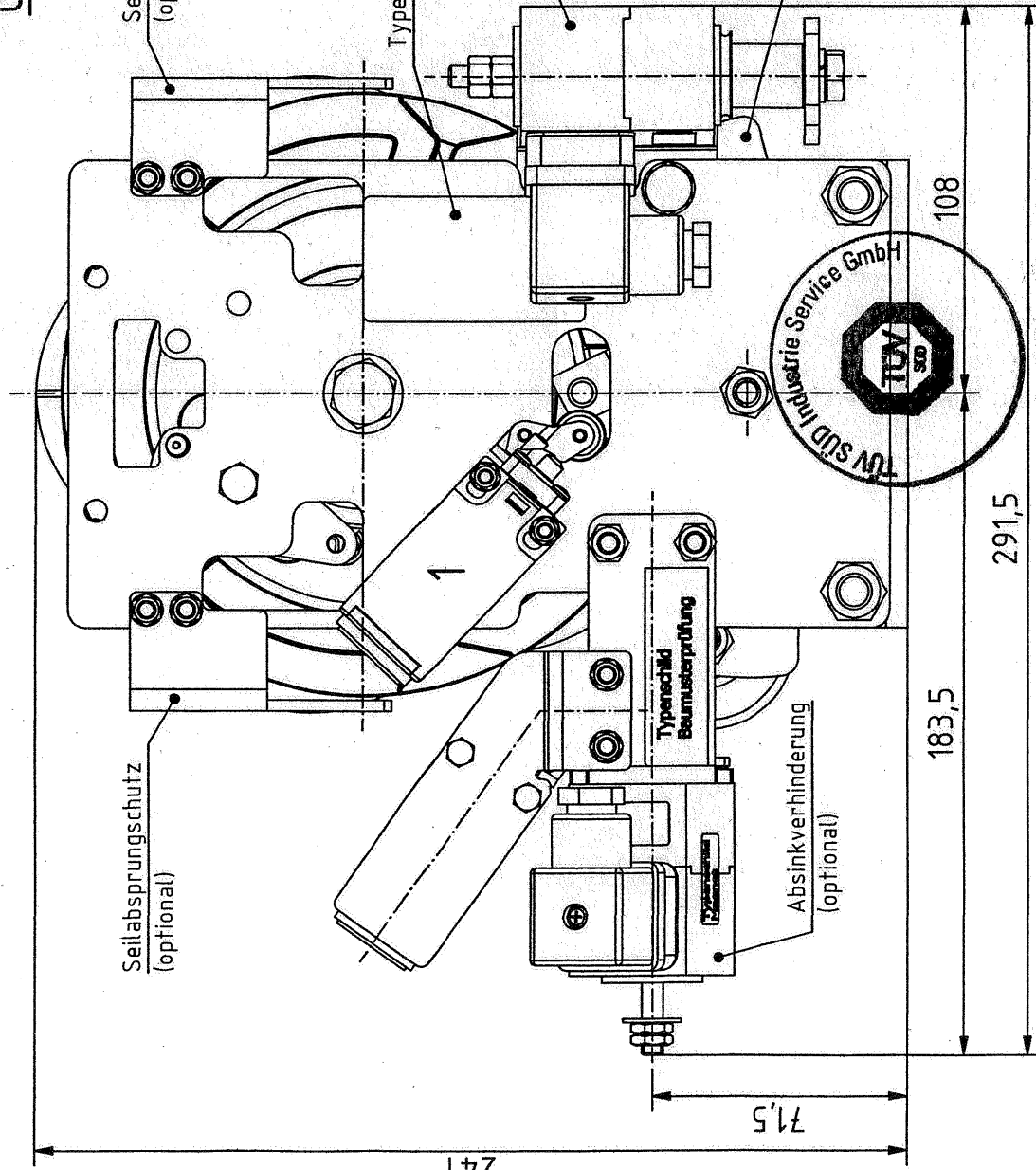

23. Mai 2014

TÜV SÜD Industrie Service GmbH
 Zentralforschung
 Abteilung Aufzüge und Sicherheitsbauteile
 Westendstr. 199, D-80686 München
 Der Sachverständige
[Signature]

- 1 = Sicherheitsschalter, rastend oder tastend
- 2 = Sicherheitsschalter, tastend

rechte Ausführung gezeichnet
 linke Ausführung spiegelbildlich

GB 160 - U - P

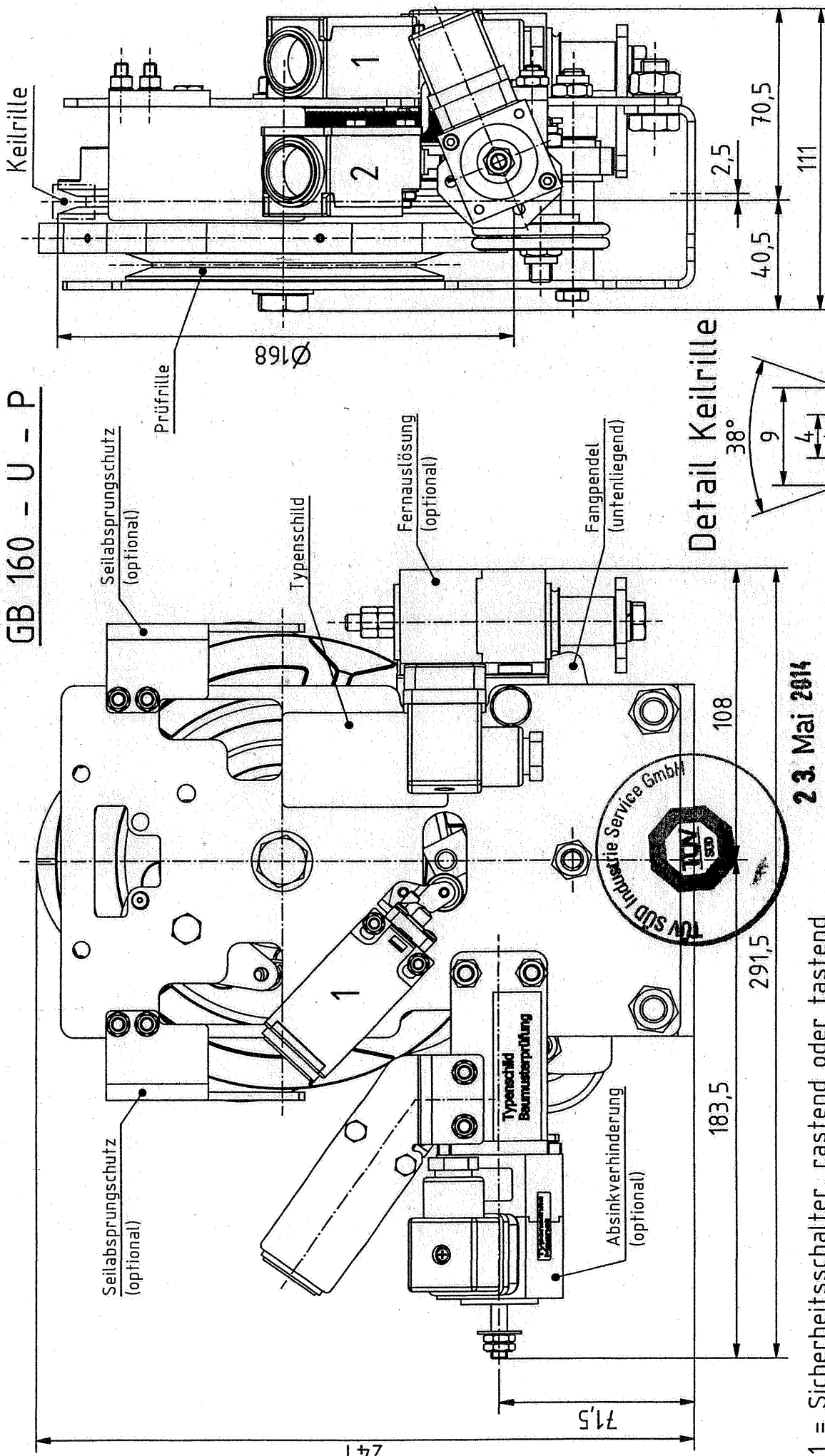

23. Mai 2014

GEPRÜFT -
 TÜV SÜD Industrie Service GmbH
 Zentralbereich Fördertechnik-Sonderbauten
 Abteilung Aufzüge und Sicherheitsbauteile
 Westendstr. 199, D-80686 München
 Der Sachverständige
H. Neumann

- 1 = Sicherheitsschalter, rastend oder tastend
- 2 = Sicherheitsschalter, tastend

rechte Ausführung gezeichnet
 linke Ausführung spiegelbildlich



Type-examination certificate

Certificate no.: ESG 264

Certification office: TÜV SÜD Industrie Service GmbH
Westendstr. 199
80686 München - Germany

**Applicant/
certificate holder:** Hans Jungblut GmbH & Co. KG
Ostheimer Straße 171
51107 Köln - Germany

Date of application: 2013-09-12

Manufacturer of the test sample: Hans Jungblut GmbH & Co. KG
Ostheimer Straße 171
51107 Köln - Germany

Product: Tripping element fixed at the overspeed governor as
a part of the protection device against unintended car
movement

Type: GB 160

Test laboratory: TÜV SÜD Industrie Service GmbH
Prüflaboratorium für Produkte der Fördertechnik
Prüfbereich Aufzüge und Sicherheitsbauteile
Westendstr. 199
80686 München - Germany

**Date and
number of the test report:** 2014-06-02
ESG 264

Examination basis: EN 81-1:1998 + A3:2009 (D)
EN 81-2:1998 + A3:2009 (D)

Result: The safety component conforms to the requirements
of examination basis for the respective scope of
application stated on page 1 - 2 of the annex to
this type-examination certificate.

Date of issue: 2014-06-03

Certification office for products of conveyor systems
Lifts and safety components

Werner Rau
Werner Rau

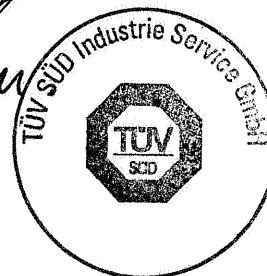



Annex to the type-examination certificate no. ESG 264 dated 2014-06-03

1 Scope of application with relation to a brand-new element

1.1 Assigned design features

- Retaining solenoid

Type	LHP035053A67			LCL040050A23	
Operating power (VDC)	24	12	12	24	205
Rated current (A)	0.98	1.95	1.41	0.66	0.09
Operating time (%)	100%				
Max. tripping speed (m/s)	1.50				
Max. feasible re-sponse distance** (mm)	118				
Established max. response time* of retaining solenoid (ms)	91	71	42	39	43

* **Response time:** Defined as the difference in time between current drop of the power supply for the solenoid retaining the blocking device and achieving the end position for the activation of the safety gear.

** **Response distance:** Defined as the max. distance that can be covered by the lift moving away from the landing position after the blocking device has engaged and as caused by delay and/or other distance losses at the overspeed governor until the tensile force has built up.

- Rope wheel diameter 168 mm
- No. of stopping options 5
- System effecting on pendulum
- Allowed direction of retraction both directions
- Tensile force ≥ 300 N

2 Conditions

- 2.1 The above mentioned safety component represents only a part of a protective equipment against unintended movement of the elevator car. Only in combination with a braking component, which must be subjected to an own type-examination, can the system created fulfil the requirements for a safety component in accordance with Annex F.8, EN 81-1:1998 + A3:2009 (D).
- 2.2 Activation of the safety component is achieved by disconnecting the power supply to the solenoid of the blocking device.
- 2.3 After the safety device has been tripped by a detection system (the process of which is not necessarily a mechanic process, but may be an electric or electro-magnetic process by way of disconnecting the power supply of the solenoid), the mechanical engagement has to be safely ensured. Therefore, at regular intervals, it is required to engage the device (e.g. daily) in order to check the movement of the blocking device. This can be achieved by using micro switches or proximity switches. In case of incomplete or defective function (non-engagement, non-release of armature plate), keep lift stopped.
- 2.4 With regard to the fulfilment of the complete design for the lift installation(s) the installer (of the lift installation) has to create test instructions in acc. w. D.2 p) of EN 81-1:1998 + A3:2009 (D), attach such test instructions to the lift documentation and provide required auxiliary means or measuring devices allowing safe examination and inspection (e.g. with the shaft doors closed).

Note: The English text is a translation of the German original. In case of any discrepancy, the German version is valid only.



Industrie Service

- 2.5 When considering the entire system, incorporate time required and implications regarding the build-up of the tensile force, its dispersion and modification over time and also take possibly emerging distances and/or delays by deflections into consideration.
- 2.6 Fast and safe rescuing of lift passengers must be possible by way of suitable technical measures; such measures have to be documented in the operation manual of the lift.
- 2.7 The installer of the lift is to be provided with a written confirmation with regard to the compliance of the component with the type-examined component as well as with regard to the warranted response distances and response times (e.g. by way of a rating plate and/or an addendum to the relevant EC Declaration of Conformity of the overspeed governor).

3 Remarks

- 3.1 This type-examination is referring only to partial requirements regarding the protective device against unintended car movement in acc. w. EN 81-1:1998 + A3:2009 (D), Section 9.11.

Not included or interface respectively are exemplary time values from the build-up of the tensile force as well as possible distances and time periods caused by mechanical deflections or electric/electronic delays to the braking element.

In addition to the design variants as represented in the identification drawing in acc. w. 3.2, it is possible to also combine other fittings to the safety device as e.g. impulse generators or sensor additions respectively.
- 3.2 In order to provide identification, information about the basic design and functioning and to show the environmental conditions and connection requirements, drawing number „Absinkverhinderung GB 160 – U“ or „Absinkverhinderung GB 160 – U – Ausführung 1“ with certification stamp dated 2014-06-03 is to be enclosed with the type-examination certificate and the annex thereto.
- 3.3 This type-examination certificate to be used only in connection with the pertinent annex and the relevant EC type-examination certificate no. AGB 264, type GB 160.

Absinkverhinderung GB 160 - U

linke Ausführung

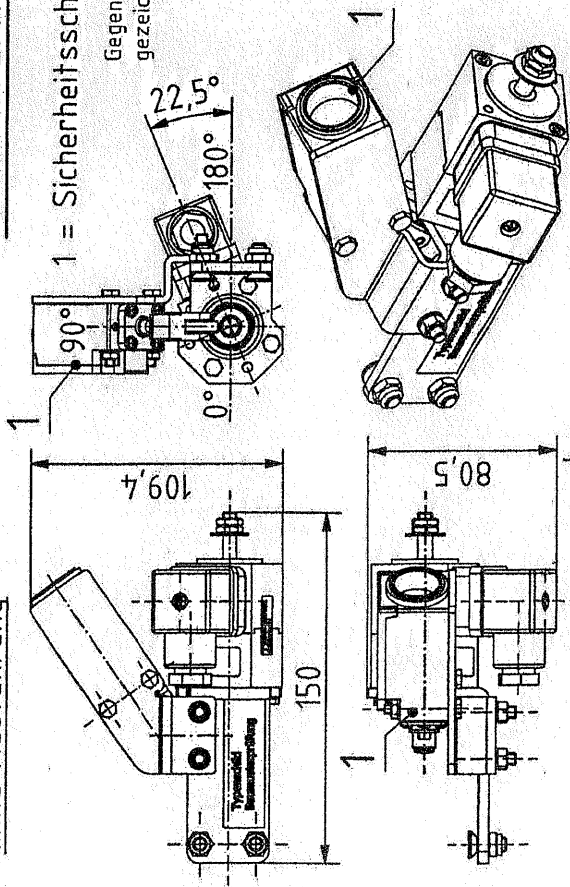

1 = Sicherheitsschalter, tastend

Gegenstecker immer in gezeichneter Position

rechte Ausführung

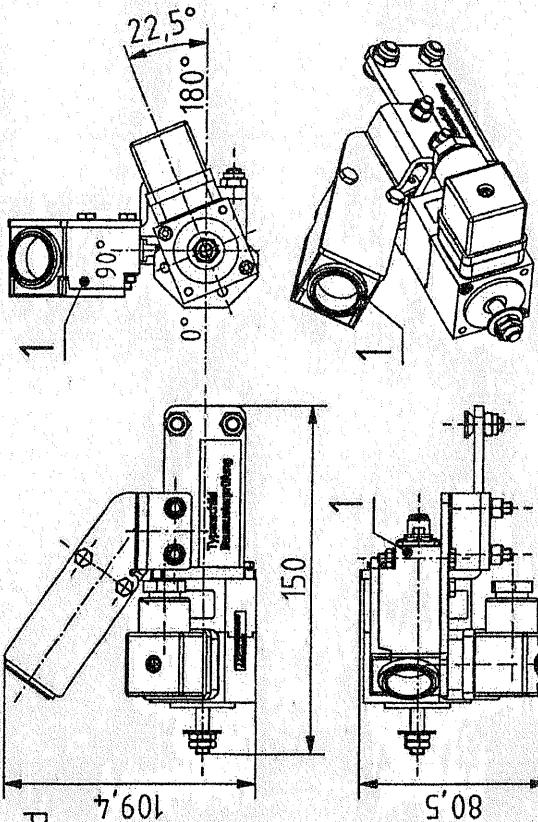

Anbaubeispiel:
GB 160 - U - LA

- 3. Juni 2014

- GEPRÜFT -
TUV SÜD Industrie Service GmbH
Zentralbereich Fördertechnik-Sonderbauten
Abteilung Aufzüge und Sicherheitsbauteile
Westendstr. 199, D-80686 München
Der Sachverständige

H. Neumann

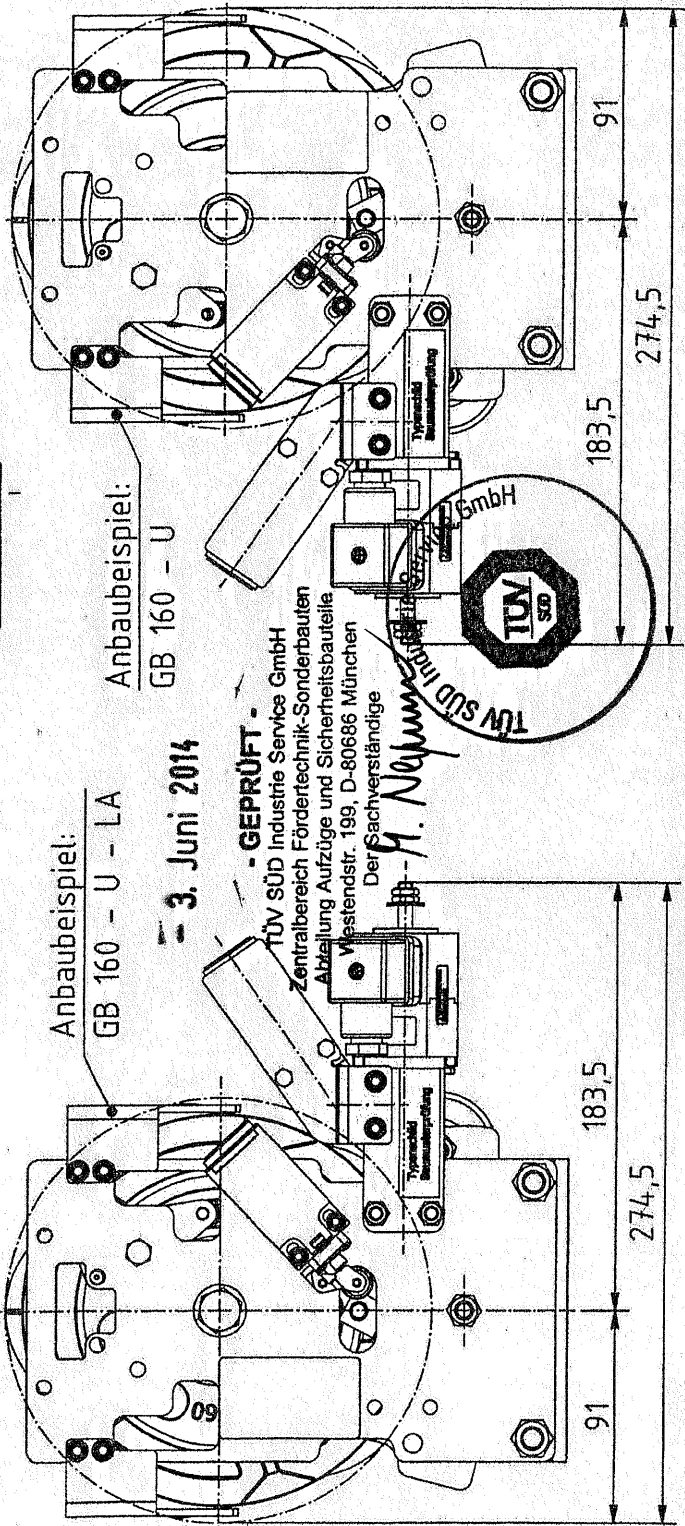

Anbaubeispiel:
GB 160 - U

Gezeichnet: K. Schmitz (09.05.2014)

Geprüft: N. Walter (09.05.2014)

Freigegeben: D. Grunau (09.05.2014)

Absinkverhinderung GB 160 - U - Ausführung 1

linke Ausführung

rechte Ausführung

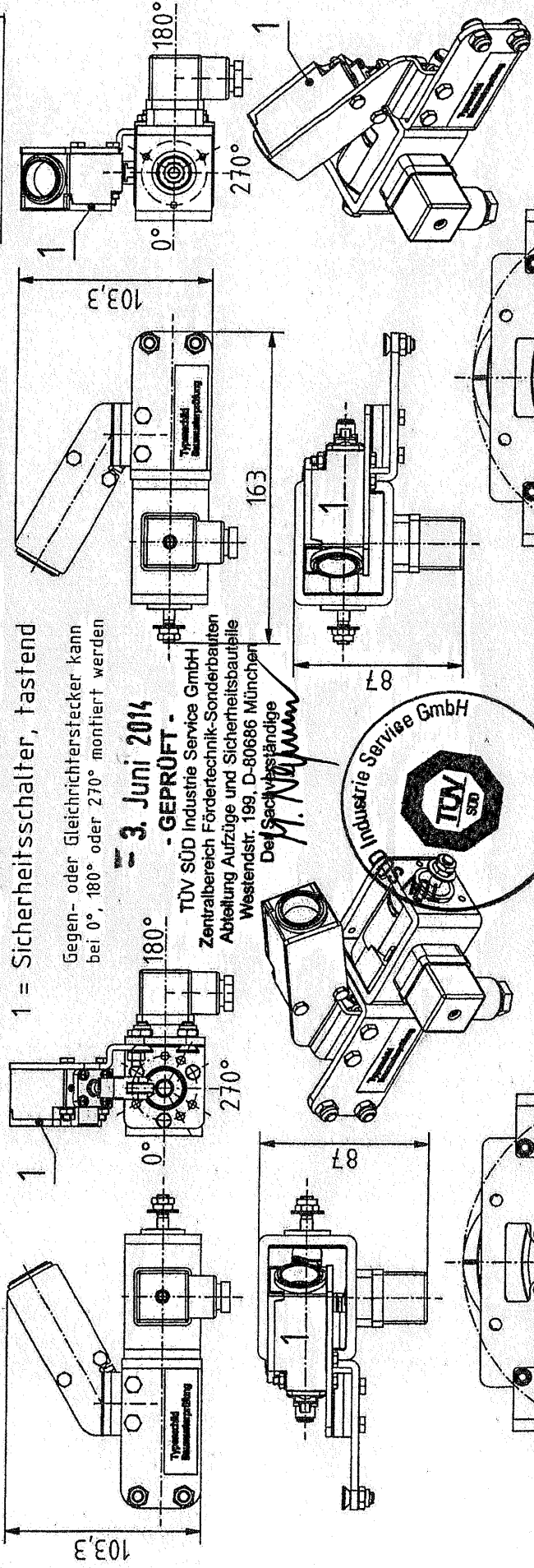

1 = Sicherheitsschalter, tastend

Gegen- oder Gleichrichterstecker kann bei 0°, 180° oder 270° montiert werden

3. Juni 2014

- GEPROFT -

TÜV SÜD Industrie Service GmbH
Zentralbereich Fördertechnik-Sonderbauten
Abteilung Aufzüge und Sicherheitsbauteile
Westendstr. 199, D-80686 München
Teil Sachverständige

M. Nijman



Anbaubeispiel:
GB 160 - U - LA

Anbaubeispiel:
GB 160 - U

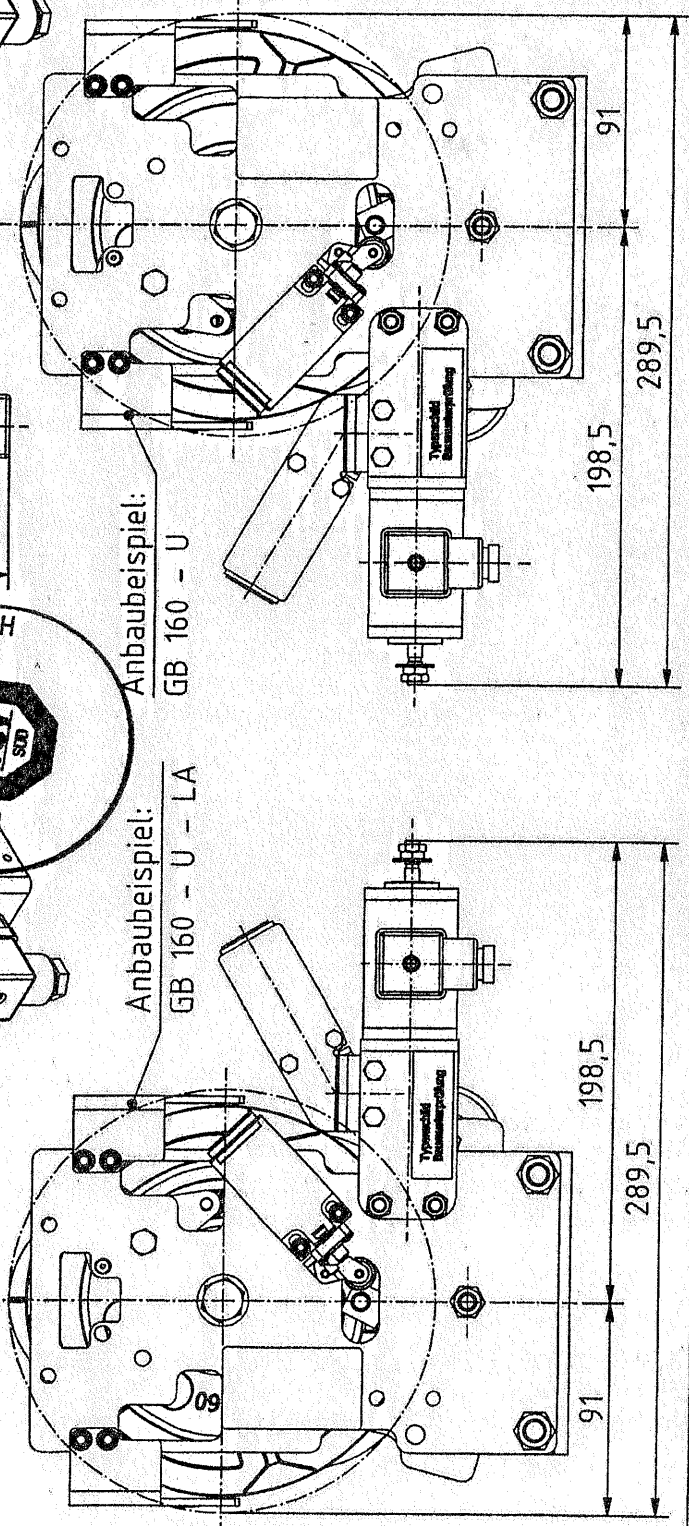

Gezeichnet: K. Schmitz (09.05.2014)

Geprüft: N. Walter (09.05.2014)

Freigegeben: D. Grunau (09.05.2014)

EC declaration of conformity

for safety components according to EC lift-directive 95/16/EC, Annex II A

Description of the safety component: Overspeed governor for actuating safety gears on lifts, stacking equipment or similar mechanical handling appliances and hoistings

Type and serial-no.: HJ 200, HJ 250, HJ 300, HJ 200 Z12, Z12, HJ 250 Z10, HJ 300 Z10, GB 160

Year of manufacture: Available at manufacturer by registered serial-no.

The safety component conforms to the following rules:

Safety rules for electric lifts	EN 81-1
Safety rules for hydraulic Lifts	EN 81-2
Machinery directive	2006/42/EC
Safety rules for stacking equipment	EN 528

Notified body for EC-type-examination: TÜV Süddeutschland Bau und Betrieb GmbH
Zertifizierungsstelle für Aufzüge und Sicherheitsbauteile
Westendstrasse 199, D-80686 München
(Identification number: 0036)

EC type-examination certificates: HJ 200: AGB 001/1, AGB 001/2, AGB 001/3
HJ 200 Z12: AGB 027/1, AGB 027/2
HJ 300: AGB 002, HJ 250 / HJ 300: AGB 002/1
Z12: AGB 031/1 HJ 250 Z10 / HJ 300 Z10: AGB 031/2
GB 160: AGB 264

Notified body for production check: TÜV Rheinland Industrie Service GmbH
Am Grauen Stein, 51105 Köln, Germany
(Identification number: 0035, old No. 0671)

Notified body for checking the quality assurance-system: see above

Date/Signature of manufacturer: 01.07.2014
Declaration to the signer:



Manager